

Panasonic®

2.4GHz Digital Cordless Phone

Operating Instructions

Model No. **KX-TG2302**

Pulse-or-tone dialing capability



**PLEASE READ BEFORE
USE AND SAVE.**

**Charge the battery for 6 hours
before initial use.**

Contents by Section

- 1 Getting Started
- 2 Making/Answering Calls
- 3 Special Features
- 4 Things You Should Know
- 5 Guía rápida

Panasonic World Wide Web address:

<http://www.panasonic.com>

for customers in the USA or Puerto Rico

Attach your purchase receipt here.

For product service

- Visit our website: <http://www.panasonic.com/support>
- Contact us via the web at: <http://www.panasonic.com/contactinfo>
- Call us at: 1-800-211-PANA(7262) or 1-800-833-9626

When you ship the product

- Carefully pack your unit, preferably in the original carton.
- Attach a letter, detailing the symptom, to the outside of the carton.

Symptom

- Send the unit to an authorized servicer, prepaid and adequately insured.
- Do not send your unit to the Panasonic Consumer Electronics Company listed below or to executive or regional sales offices. These locations do not repair consumer products.

**If you need assistance with the setup or operation,
please call 1-800-211-PANA(7262)**

For hearing or speech impaired TTY users, TTY : 1-877-833-8855

**Panasonic Consumer Electronics Company,
Division of Matsushita Electric Corporation of America**
One Panasonic Way, Secaucus, New Jersey 07094

**Panasonic Sales Company,
Division of Matsushita Electric of Puerto Rico, Inc.**
Ave. 65 de Infantería, Km. 9.5, San Gabriel Industrial Park
Carolina, Puerto Rico 00985

© 2004 Panasonic Communications Co., Ltd. All Rights Reserved.

PQQX13980YA S1203-1014

1-A Accessories

- AC Adaptorone
Order No.
PQLV1Z
(PQLV1)
- Telephone Line Cordone
Order No.
PQJA10075Z
- Battery.....one
Order No.
HHR-P104
- Handset Cover.....one
Order No.
PQKK10140Z2
- Belt Clip.....one
Order No.
PQKE10375Z2
- Shoulder Rest Attachment.....one
Order No.
PQKE10364Z1

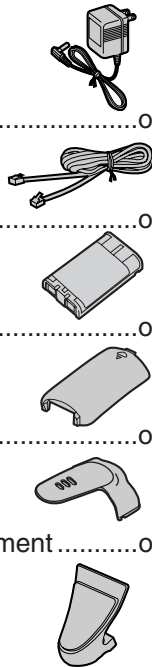

1-B Location of Controls

Handset

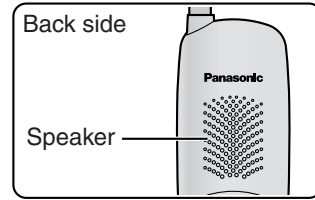

- Antenna
- Receiver
- RECHARGE Indicator (4-A)
- [OFF] Button (2-A)
- [REDIAL] Button (2-A)
- VOL. (VOLUME) Key ([▼], [▲]) (2-A, 2-B)
- [VOICE ENHANCER] Button and Indicator (1-C, 2-A)
- Microphone (2-A)
- Charge Contacts (4-A)
- Back side
- Speaker
- TALK Indicator (2-A, 2-B)
- [TALK] Button (2-A)
- [SP-PHONE] (Speakerphone) Button (2-A)
- Headset Jack (4-D)
- [*] (TONE) Button (3-B)
- [FLASH/CALL WAIT] Button (3-C, 3-D)

Base unit

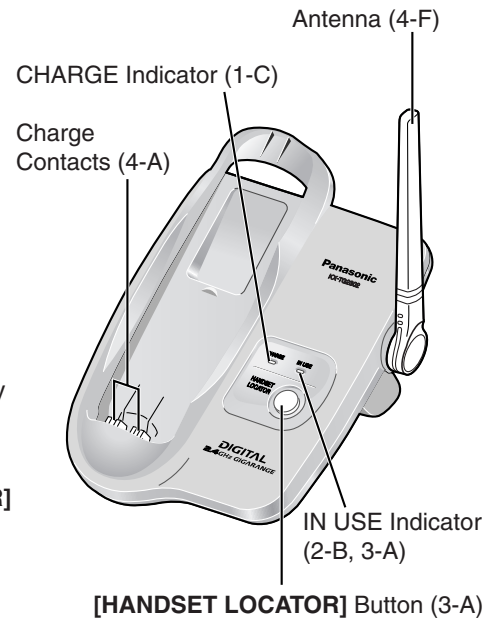

For extra orders, call 1-800-332-5368.
For hearing or speech impaired TTY users, call 1-866-605-1277.

1-C Settings

1 Connect as shown.

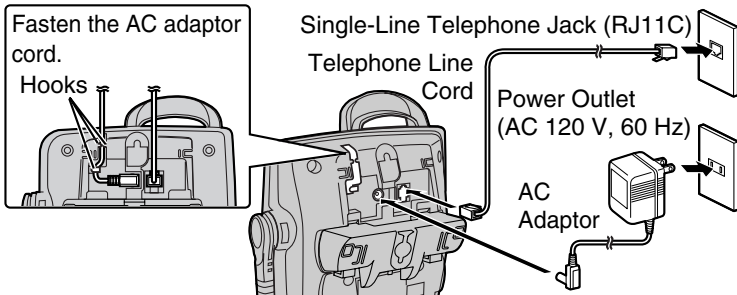

- USE ONLY WITH Panasonic AC ADAPTOR PQLV1 (Order No. PQLV1Z).
- The AC adaptor must remain connected at all times. (It is normal for the adaptor to feel warm during use.)
- The unit will not work during a power failure. We recommend connecting a standard telephone to the same telephone line or to the same telephone jack using the Panasonic KX-J66 T-adaptor.

To select the dialing mode TONE (preset) or PULSE

Make sure the handset and base unit are not being used. The handset must be operated near the base unit and while off the base unit.

1. Press [VOICE ENHANCER], then press [8].
 - The VOICE ENHANCER indicator flashes.
2. To select PULSE, press [1].
OR
To select TONE, press [2].
3. Press [VOICE ENHANCER].
 - The handset beeps and the indicator light goes out.

2 Insert the battery (1), and press it down until it snaps into the compartment (2). Close the cover.

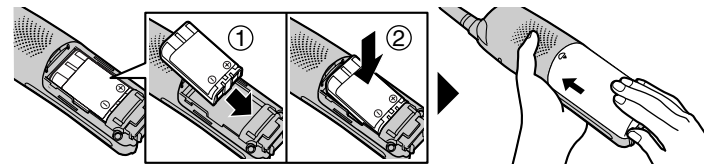

To replace the battery:

Press the notch on the cover firmly and slide it as indicated by the arrow. Replace the old battery with a new one (4-A). Close the cover and charge the battery for 6 hours.

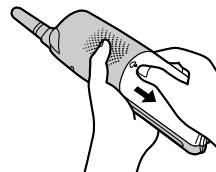

3 Charge the battery for 6 hours.

- See section 4-A for more details.
- The unit beeps once and the CHARGE indicator lights.

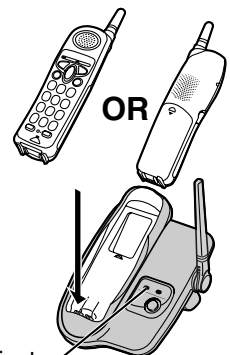

CHARGE Indicator

2-A Making Calls

- 1 Press [↶] then dial a phone number.
OR
To have a hands-free phone conversation, press [SP-PHONE] and dial a phone number. When the other party answers, talk into the microphone.
 - The TALK indicator lights.
 - If an alarm tone sounds, see section 4-H.

- 2 To hang up, press [OFF] or place the handset on the base unit.
 - The indicator light goes out.

- For the best operating performance, see section 4-F.

To redial the last number dialed

Press [↶] or [SP-PHONE], then press [REDIAL].

To adjust the receiver/speaker volume during a conversation

There are 3 volume levels for the receiver and 6 volume levels for the speaker.

To increase volume, press [▲]. To decrease volume, press [▼].

- If you try to increase/decrease volume when it is at the maximum/minimum level, the handset will beep 3 times.

Lighted handset keypad

The handset dialing buttons will light for a few seconds after pressing a button or lifting the handset off the base unit.

Voice Enhancer Technology

Panasonic's Voice Enhancer Technology clarifies the voice of the person you are talking to, reproducing a more natural-sounding voice that is easier to hear and understand.

Voice Enhancer Technology can be turned on or off. The factory preset is OFF.

- Depending on the condition and quality of your telephone line, Voice Enhancer may emphasize existing line noise. If it becomes difficult to hear the caller, turn this feature off.

To turn this feature on, press [VOICE ENHANCER] during a conversation.

- The indicator lights in talk or speakerphone mode.
- The indicator light goes out after hanging up a call, but this feature still remains on.
- To turn this feature off**, press [VOICE ENHANCER] again. The indicator light goes out.

2-B Answering Calls

When a call is received, the handset rings, and the TALK indicator on the handset and the IN USE indicator on the base unit flash rapidly.

If the handset is off the base unit, press [↶] or [SP-PHONE].

- You can also answer a call by pressing any button except [▼], [▲] or [OFF].

OR

If the handset is on the base unit, just lift up.

Selecting the ringer volume

Make sure the handset and base unit are not being used. The handset must be operated near the base unit and while off the base unit.

- To select high (preset), medium, or low**, press [▼] or [▲] to select volume. The volume will change and ring. To stop ringing, press [OFF] or [VOICE ENHANCER].
- To turn the ringer off**, press and hold [▼] until 2 beeps sound.
- To turn the ringer on**, press [▼] or [▲]. The handset will ring at the low level.
- You can adjust the ringer volume while a call is ringing. Press [▼] or [▲] while the handset is ringing. To turn the ringer off, press and hold [▼] until 2 beeps sound.

Temporary ringer off

While the handset is ringing for an outside call, you can turn the ringer off temporarily by pressing [OFF]. The handset will ring again as normal the next time a call is received.

Selecting the ringer tone

Make sure the unit is not being used and the handset is lifted off the base unit. 7 ringer tones are available (3 bell ringer patterns and 4 melody patterns).

- If you subscribe to a Distinctive Ring Service (such as IDENTARING) from your telephone company with 2 or 3 consecutive rings, select a bell ringer pattern (1 to 3). If you select a melody pattern, you will not be able to distinguish lines by their ringers.
- If you select one of the melody ringer patterns, the ringer will continue to sound for several seconds if:
 - the caller hangs up before you answer the call, or
 - another person answers the call using another phone connected on the same line.

Press [▼] or [▲], then select the desired ringer tone by pressing [1] (preset) to [7].

[1] to [3]: Bell ringer patterns [4] to [7]: Melody patterns

- After pressing [▼] or [▲], the handset will ring using the current ringer tone.
- The handset will ring and the ringer tone will change.
- To stop ringing, press [OFF] or [VOICE ENHANCER].

3 Special Features

3-A Handset Locator

You can locate the handset or page the handset user with beep tones from the base unit.

1. Press **[HANDSET LOCATOR]** on the base unit.
 - The TALK indicator on the handset and the IN USE indicator on the base unit flash rapidly, and the handset beeps for 1 minute.
2. To stop paging, press **[HANDSET LOCATOR]** again or press **[OFF]** on the handset.
 - You can also stop paging on the handset by pressing any button except **[▼]** or **[▲]**.

3-B Temporary Tone Dialing (For Rotary or Pulse Service Users)

Press **[*]** (TONE) before entering access numbers which require tone dialing.

- The dialing mode changes to tone. You can enter numbers to access an answering service, electronic banking service, etc. When you hang up, the dialing mode will return to pulse.

3-C For Call Waiting Service Users

Press **[FLASH/CALL WAIT]** if you hear a call waiting tone during a conversation.

- The first call is put on hold and you can answer the second call.
- To return to the first caller, press **[FLASH/CALL WAIT]** again.
- If this function does not operate properly, consult your telephone company for details.

3-D FLASH Button

Pressing **[FLASH/CALL WAIT]** allows you to use special features of your host PBX such as transferring an extension call, or accessing optional telephone services such as call waiting.

- Pressing **[FLASH/CALL WAIT]** cancels Temporary Tone Dialing mode.

3-E Re-registering the Handset

If an alarm tone sounds when you press **[↶]**, **[SP-PHONE]** or **[VOICE ENHANCER]** even when using the handset near the base unit, the handset may have lost communication with the base unit. You need to re-register the handset to the base unit.

- **Have both the handset and base unit nearby during registration.**
- **Follow steps 1 and 2 listed below. You have about 1 minute to complete them.**

1. *Base unit:* Press and hold **[HANDSET LOCATOR]**.
 - The CHARGE indicator flashes.
 2. *Handset:* Press and hold **[FLASH/CALL WAIT]** until a beep sounds.
 - The VOICE ENHANCER indicator flashes.
 - When registration is complete, a beep sounds from the handset and the indicator lights go out.
 - **Wait for 20 seconds after registration is complete while the handset establishes communication with the base unit.**
- If the handset beeps 3 times in step 2, an error occurred. Try again from step 1.
 - You can stop registration by pressing **[OFF]** on the handset, and pressing **[HANDSET LOCATOR]** on the base unit.

4 Things You Should Know

4-A Battery

Recharge

When the RECHARGE indicator flashes or the handset beeps intermittently, place the handset on the base unit for 6 hours to recharge the battery.

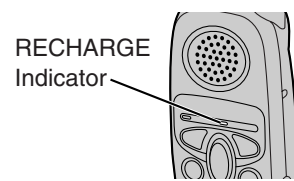

- The RECHARGE indicator will flash when the handset battery is charged less than 15 minutes and the handset is lifted off the base unit.

Battery replacement:

If you cleaned the charge contacts and fully charged the battery, but after a few telephone calls, the RECHARGE indicator flashes, the battery may need to be replaced. Please order a new Panasonic HHR-P104 battery at the telephone number shown on section 1-A. To replace the battery, see section 1-C, step 2.

A nickel metal hydride battery that is recyclable powers the product you have purchased. Please call 1-800-8-BATTERY for information on how to recycle this battery.



Battery information

After your Panasonic battery is fully charged, you can expect the following performance:

Operation	Operating time
While in use (TALK)	Up to about 5 hours
While not in use (Standby)	Up to about 11 days

- A fully charged battery will give you up to 5 hours of continuous talk time, or keep your handset in Standby mode to receive incoming calls for up to 11 days (if no phone calls are made). Battery power is consumed whenever the handset is off of the base unit, even when the handset is not in use. The longer you leave the handset off of the base unit, the time you can actually talk on the handset will be shortened. Actual battery performance depends on a combination of how often the handset is in TALK mode and how often it is in Standby mode.
- If the battery is fully charged, you do not have to place the handset on the base unit until the RECHARGE indicator flashes. This will maximize the battery life.
- If you want to keep the battery fully charged at all times, place the handset on the base unit when the handset is not used. The battery cannot be overcharged.
- **Clean the charge contacts of the handset and the base unit with a soft, dry cloth once a month. Clean more often if the unit is subject to grease, dust or high humidity.** Otherwise the battery may not charge properly.

4-B Belt Clip

You can hang the handset on your belt or pocket using the included belt clip.

To attach the belt clip

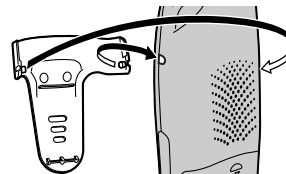

To remove the belt clip

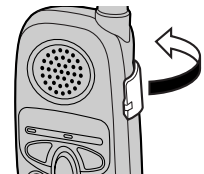



4-C Shoulder Rest Attachment

Use the shoulder rest attachment if you need to keep your hands free during a phone conversation.

To attach the shoulder rest attachment

Attach the included belt clip to the handset (4-B), then attach the shoulder rest attachment to the belt clip as shown below. You will hear a click when the shoulder rest attachment is in place.

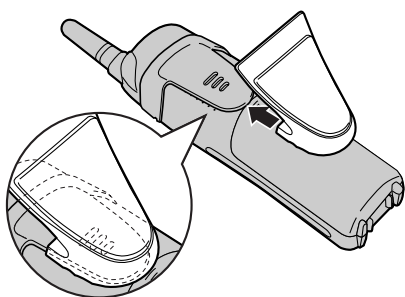

To remove the shoulder rest attachment

Slide the base of the attachment in the direction of the arrow as shown below.

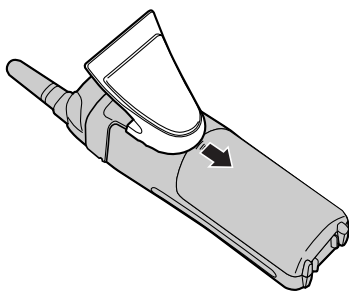

4-D Optional Headset

Connecting an optional headset to the handset allows hands-free phone conversation. Please use only a Panasonic KX-TCA60, KX-TCA86, KX-TCA88, KX-TCA88HA, KX-TCA91, KX-TCA92, or KX-TCA98 headset.

To order, call the accessories telephone number on section 1-A.

Connecting an optional headset

Open the headset jack cover, and insert the headset plug into the headset jack as shown below.

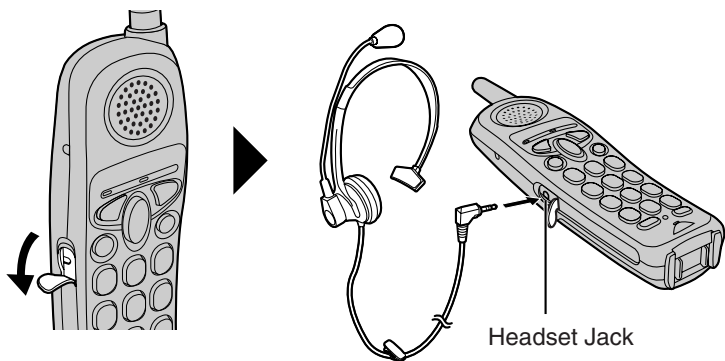

• Headset sold separately. Model shown here is KX-TCA88.

To switch to the speakerphone while using the headset:
Press [SP-PHONE]. To return to the headset, press [↶].

4 Things You Should Know



4-E Wall Mounting

This unit can be mounted on a wall phone plate.

- 1 Press the tabs in the direction of the arrows (①), then remove the wall mounting adaptor (②).

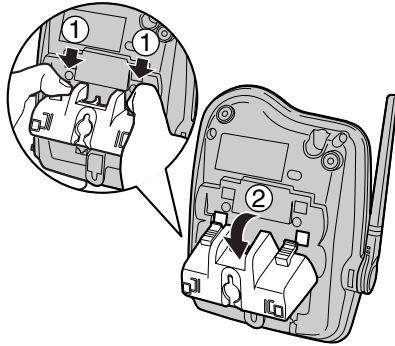

- 2 Connect the AC adaptor.
 - Fasten the AC adaptor cord to prevent it from being disconnected.

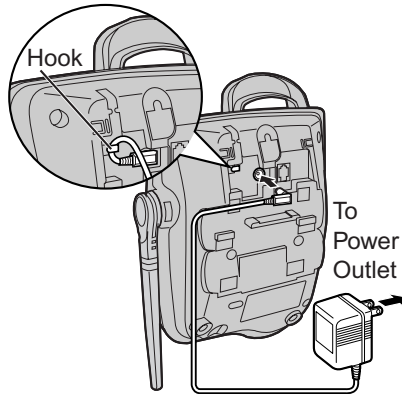

- 3 Tuck the telephone line cord inside the wall mounting adaptor, then push the adaptor in the direction of the arrows (① and ②) while pressing the tabs.
 - The word "UP WALL" should face upward.

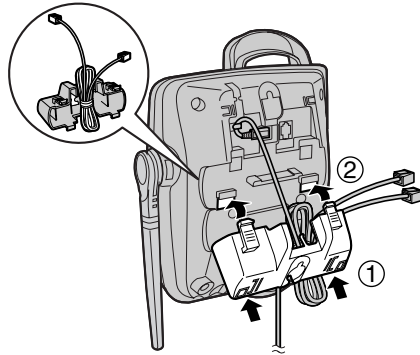

- 4 Connect the telephone line cord. Mount the unit, then slide it down.
 - Raise the antenna.

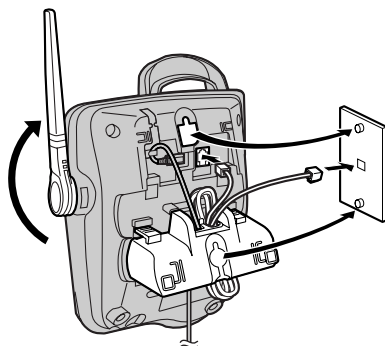

- 5 **To charge the handset battery:**
Place the handset on the base unit.
 - The unit beeps once and the CHARGE indicator lights.

4-F Base Unit Location/Noise

Calls are transmitted between the base unit and handset using wireless radio waves. **For maximum distance and noise-free operation**, the recommended base unit location is:

Away from electrical appliances such as a TV, personal computer or another cordless phone.

In a HIGH and CENTRAL location with no obstructions such as walls.

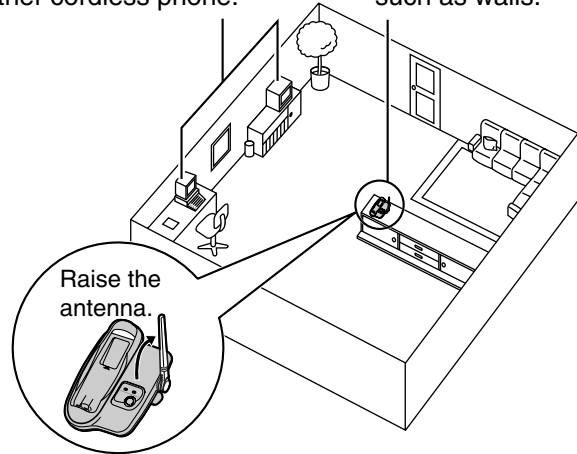

Note:

- If you use the handset near a microwave oven which is being used, noise may be heard from the receiver or the speaker. Move away from the microwave oven and closer to the base unit.
- If you use the handset near another cordless phone's base unit, noise may be heard. Move away from the other cordless phone's base unit and closer to your base unit.

4-G Specifications

■ Base unit

Power Supply:	AC Adaptor (120 V AC, 60 Hz)
Power Consumption:	Standby: Approx. 2.1 W Maximum: Approx. 5.0 W
Frequency:	2.4 GHz–2.48 GHz
Dimensions (H x W x D):	Approx. 124 mm x 155 mm x 174 mm (4 7/8" x 6 3/32" x 6 27/32")
Mass (Weight):	Approx. 330 g (0.73 lb.)

■ Handset

Power Supply:	Ni-MH battery (3.6 V, 830 mAh)
Frequency:	2.4 GHz–2.48 GHz
Dimensions (H x W x D):	Approx. 208 mm x 52 mm x 39 mm (8 3/16" x 2 1/16" x 1 17/32")
Mass (Weight):	Approx. 190 g (0.42 lb.)
Security Codes:	1,000,000

■ Dialing Mode:

Tone (DTMF)/Pulse

■ Operating Environment:

5°C–40°C (41°F–104°F)

Specifications are subject to change without notice.

4-H Troubleshooting

Problem	Cause & Remedy
The unit does not work.	<ul style="list-style-type: none"> • Check the settings (1-C). • Check whether the dialing mode setting is correct (1-C). • Fully charge the battery (4-A). • Clean the charge contacts and charge again (4-A). • Check battery installation (1-C). • Unplug the AC adaptor to reset it. Plug in, and try again. • Re-install the battery (1-C) and fully charge it.
An alarm tone sounds when you press [↵], [SP-PHONE] or [VOICE ENHANCER].	<ul style="list-style-type: none"> • You are too far from the base unit. Walk closer to the base unit and try again. • Confirm the AC adaptor is plugged in. • Raise the base unit antenna. • If the above remedies do not solve the problem, the handset may have lost communication with the base unit. Register the handset again (3-E).
Static, sound cuts in/out, fades. Interference from other electrical units.	<ul style="list-style-type: none"> • Move the handset and the base unit away from other electrical appliances (4-F). • Walk closer to the base unit. • Raise the base unit antenna.
The handset does not ring.	<ul style="list-style-type: none"> • The ringer volume is turned off. Set to high, medium, or low (2-B).
You cannot redial.	<ul style="list-style-type: none"> • If the last number dialed was more than 48 digits long, the number will not be redialed correctly.
You cannot make long distance calls.	<ul style="list-style-type: none"> • Please make sure you have long distance service.
You cannot page the handset.	<ul style="list-style-type: none"> • The handset is too far from the base unit or is engaged in an outside call. Try again later.

Problem	Cause & Remedy
[FLASH/CALL WAIT] does not work properly.	<ul style="list-style-type: none"> • Set the flash time. Press [VOICE ENHANCER], [9] and [8], then press [VOICE ENHANCER] again.
The RECHARGE indicator flashes or the unit beeps intermittently.	<ul style="list-style-type: none"> • Fully charge the battery (4-A).
You charged the battery fully, but the RECHARGE indicator continues to flash.	<ul style="list-style-type: none"> • Clean the charge contacts and charge again (4-A). • The battery may need to be replaced. If you install a new battery, fully charge it (1-C).
The CHARGE indicator light does not go out after the battery has been charged.	<ul style="list-style-type: none"> • This is normal.
You cannot have a conversation using the headset.	<ul style="list-style-type: none"> • Make sure the optional headset is connected properly (4-D). • [SP-PHONE] may have been pressed. Press [↵] to switch to the headset.
If you cannot solve your problem	<ul style="list-style-type: none"> • Visit our website: http://www.panasonic.com/support • Contact us via the web at: http://www.panasonic.com/contactinfo • Call our customer call center at: 1-800-211-PANA(7262)

4-I Helpful Information

- **Environment**—do not place the unit in a room where the temperature is less than 5°C (41°F) or greater than 40°C (104°F). Allow 10 cm (4") clearance around the unit for proper ventilation. Avoid excessive smoke, dust, mechanical vibration, shock, or direct sunlight.
- **Medical**—consult the manufacturer of any personal medical devices, such as pacemakers or hearing aids, to determine if they are adequately shielded from external RF (radio frequency) energy. (The unit operates in the frequency range of 2400MHz to 2481MHz, and the power output level can range 0.04 to 0.1 watts.) Do not use the unit in health care facilities if any regulations posted in the area instruct you not to do so. Hospitals or health care facilities may be using equipment that could be sensitive to external RF (radio frequency) energy.
- **Routine care**—wipe the unit with a soft cloth. Do not use benzine, thinner, or any abrasive powder. When you leave the unit unused for a long period of time, unplug the AC adaptor from the outlet.
- **If there is any trouble**—disconnect the unit from the telephone line and connect a known working phone. If the known working phone operates properly, have your unit repaired by one of the authorized Panasonic Factory Service Centers. If the known working phone does not operate properly, consult your telephone company.

- This cordless telephone is designed for use in the United States of America. Sale or use of this product in other countries may violate local laws.
- Ce téléphone sans fil est conçu pour être utilisé aux États-Unis d'Amérique. La vente ou l'emploi de cet appareil dans certains autres pays peut constituer une infraction à la législation locale.
- Este teléfono inalámbrico fue elaborado para uso en los Estados Unidos de América. La venta o el empleo de este producto en ciertos países puede constituir violación de la legislación local.
- このコードレス電話機は、日本国外での使用を目的として設計されており、日本国内での使用は法律違反となります。従って、当社では日本国内においては原則として修理などのサービスは致しかねます。

For your future reference

Serial No. _____ Date of purchase _____
 (found on the bottom of the unit)

Name and address of dealer _____

5-A Preparación

1 Conecte como se muestra.

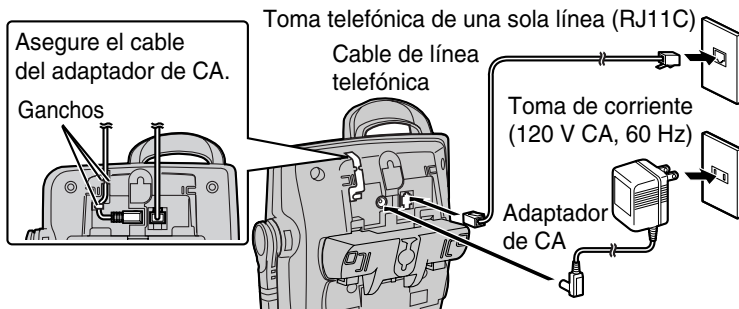

Para obtener el máximo alcance y un funcionamiento sin ruidos, ponga la unidad base en un lugar ELEVADO y CÉNTRICO sin obstrucciones ni interferencias de aparatos eléctricos.

• El adaptador de CA debe permanecer conectado en todo momento.

2 Inserte la batería (①), y presionela hacia abajo hasta que se acomode en el compartimiento (②). Cierre la cubierta.

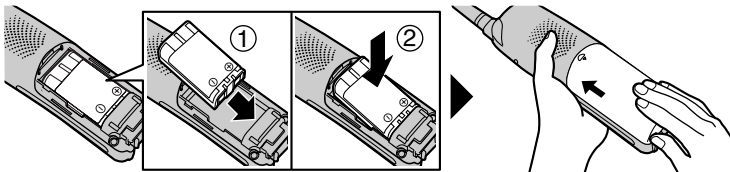

3 Cargue la batería durante unas 6 horas.

• La unidad emite un pitido y el indicador CHARGE se ilumina.

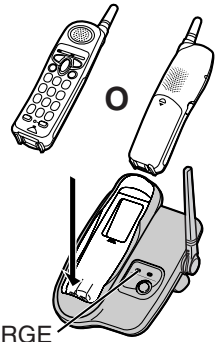

Indicador CHARGE

Para seleccionar el modo de marcación por TONO (preajustado) o PULSACIÓN

Asegúrese de que la unidad portátil y la unidad base no se están utilizando. La unidad portátil debe operarse cerca de la unidad base, y descolgada de la misma.

1. Presione [VOICE ENHANCER], y luego presione [8].
2. Para seleccionar PULSACIÓN, presione [1].
○
Para seleccionar TONO, presione [2].
3. Presione [VOICE ENHANCER].

5-B Funcionamiento

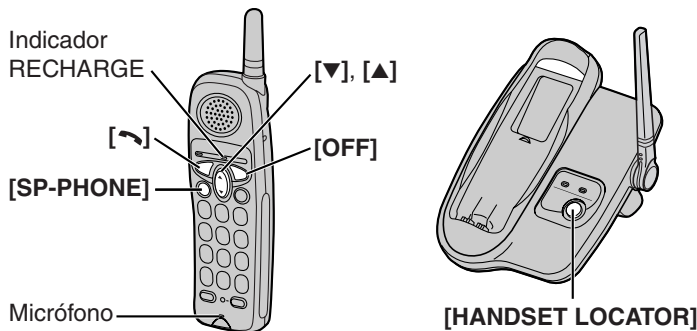

• Cuando el indicador RECHARGE parpadea o la unidad portátil emite un pitido intermitente, coloque la unidad portátil sobre la unidad base durante 6 horas para recargar la batería.

Para hacer llamadas

1. Presione [📞] y luego marque el número de teléfono.
○
Para tener una conversación con las manos libres, presione [SP-PHONE] y marque el número de teléfono. Cuando la otra persona conteste, hable dirigiéndose hacia el micrófono.
2. Para colgar, presione [OFF] o ponga la unidad portátil en la unidad base.

Para contestar llamadas

Si la unidad portátil no está en la unidad base, presione [📞], [SP-PHONE] o cualquier tecla excepto [▼], [▲] u [OFF].

○
Si está en la unidad base, levántela solamente.

Para seleccionar el volumen del timbre

Asegúrese de que la unidad portátil y la unidad base no se están utilizando. La unidad portátil debe operarse cerca de la unidad base, y descolgada de la misma.

- Para seleccionar alto (preajustado), medio o bajo, presione [▼] o [▲] para seleccionar el volumen. El volumen será cambiado y el timbre sonará a tal volumen. Para silenciar el timbre, presione [OFF] o [VOICE ENHANCER].
- Para apagar el timbre, mantenga presionado [▼] hasta que suenen 2 pitidos.
- Para encender el timbre, presione [▼] o [▲]. La unidad portátil sonará a bajo volumen.

Desactivación temporal del timbre

Mientras la unidad portátil suena al recibir una llamada externa, se puede desactivar temporalmente el timbre presionando [OFF]. La unidad portátil volverá a sonar de nuevo normalmente la próxima vez que se reciba una llamada.

Localización de la unidad portátil

Presione [HANDSET LOCATOR] en la unidad base.

- La unidad portátil emite pitidos durante 1 minuto.
- Para detener la localización, presione de nuevo [HANDSET LOCATOR] o presione [OFF] en la unidad portátil.